

**MITSUBISHI MARINE**

# S12R

**OUTPUT MARINE PROPULSION 940~1040 kW**



## MARINE PROPULSION

### ***Economic Operation***

All Mitsubishi engines are designed and built to deliver performance as well as fuel efficiency. From the combustion chamber design to the fuel injection technology, to the turbocharger and the advanced cooling system...everything has been perfectly balanced to provide a highly economic operation and optimum fuel consumption across the entire power curve.

### ***Easy Maintenance***

With Mitsubishi's S12R marine engine, maintenance is very easy. Each cylinder has its own cylinder head and the engine has large inspection covers on the crankcase. No auxiliary component requires separate lubrication, whether it's the fuel injection pump, the governor, the water pump or the turbocharger.

### ***Approved by All Major Classification Societies***

At our ISO certified manufacturing facilities, every Mitsubishi S12R diesel engine is built to meet the highest quality standards. All major marine classification societies, as recognized by Lloyd's Register of Shipping and other major international marine classifications.

### ***Environmental Compatibility***

Mitsubishi offers a full line-up of engines that comply with IMO and EPA emissions standards.

### ***Local Support Around The Globe***

A team of support specialists is available worldwide to ensure that service and maintenance are performed without delay.

**MITSUBISHI ENGINE NORTH AMERICA, INC.  
1250 GREENBRIAR DRIVE, SUITE E, ADDISON, IL 60101  
P: 630.268.0750 F: 630.268.9293 [www.mitsubishi-engine.com](http://www.mitsubishi-engine.com)**



# mitsubishi MARINE

## S12R

## -Y2MPTK

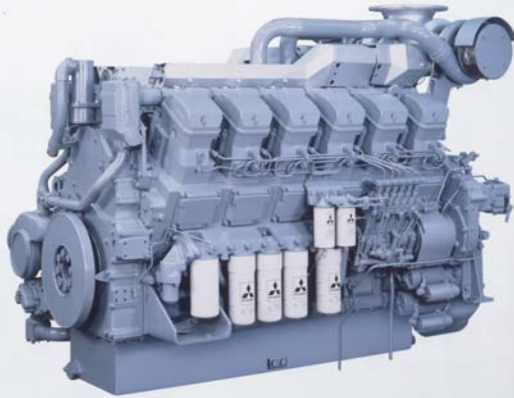

### Type

4-cycle, watercooled, turbocharged diesel engine  
MPTK with intercooler, cooled by (fresh) water of max 32°C

### Combustion System

Direct Injection

### Cylinder Arrangement

60° V, 12-Cylinder

### Bore x Stroke - inches (mm)

6.69 (170) x 7.09 (180)

### Total Displacement - in<sup>3</sup> (ltr)

2,992 (49.0)

### Compression Ratio

14.0 : 1

### Rotation

SAE Standard (Counter-Clockwise Viewed from Flywheel End)

### Starting System

Electric Motor, 24 Volt - 7.5kW (x2)

### Flywheel

SAE 21

### Flywheel Housing

SAE #00

### Fuel Oil

Diesel Fuel, ASTM D975, No. 1-D, No. 2-D

### Dry Weight - lbs (kg)

11,532 (5230)

11,731 (5320)

**EPA CERTIFIED**

### Output Marine Propulsion



Heavy Duty

Medium Duty

### HP (kWm) @ RPM

1260 (940) @ 1600

1394 (1040) @ 1640

## Outside Dimensions

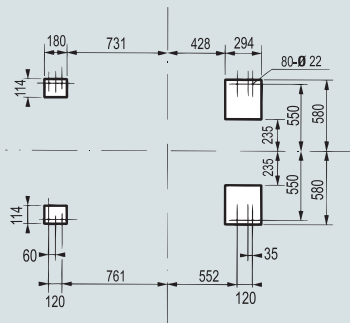

Dimensions in millimeters (1 inch = 25.4mm)

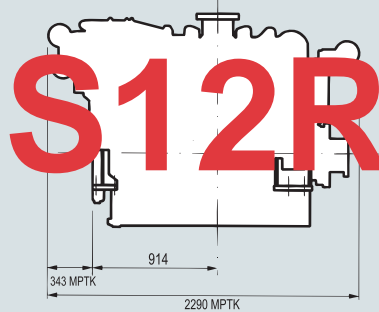

General Dimensions for reference only, not to be used for installation. See specific model drawings for further details.

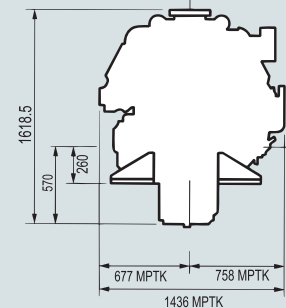

## Standard Engine Equipment

### Fuel System

Flexible fuel supply and return hoses, fuel feed pumps, MHI fuel injection pumps, single-wall fuel injection lines, fuel injectors, overflow valve.

### Lubricating Oil System

Wet type oil pan, oil pressure pump (gear driven), full-flow lubricating oil filters, by-pass filter, oil cooler with thermostat, piston cooling through oil injectors.

### Cooling System

Fresh water pump, thermostats with by-pass

### 24 Volt Electric System Earth Floated

Starter motors (2 x 7.5kW), battery charging alternator (30 amp), energize-to-stop (ETS) stop solenoid

### Air Intake and Exhaust System

Mitsubishi turbochargers with vertical exhaust outlet, air inlet silencers with pre-cleaner, inlet air aftercoolers or intercoolers, inlet manifolds, dry

### General

Hydraulic Woodward PSG governor with oil supply system, mounting brackets, flywheel and housing SAE standard, torsional vibration damper, parts catalog and owners manual

Mitsubishi Engine, their respective logos as well as corporate or product identity used herein, are trademarks of Mitsubishi and may not be used without prior written consent.

Distributed By:



Contents are subject to change without prior notice

MLEMB 10-09