

Kubota

# KUBOTA DIESEL ENGINE SUPER FIVE SERIES

E-TVCS

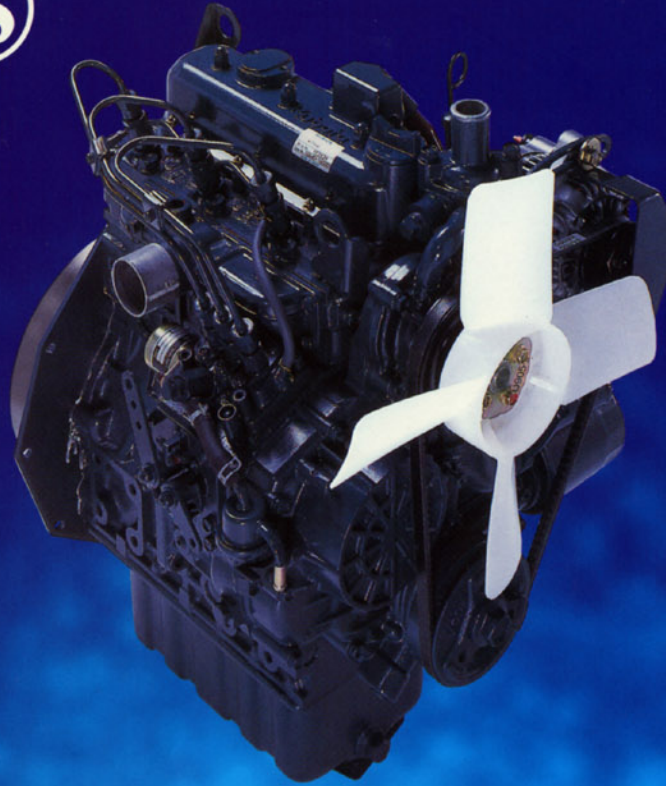

EPA Tier I Certified

*Liquid-Cooled Diesel Engine*

*Displacement Range: 898 cc to 1498 cc*

*Maximum Output Range: 14.0 kW to 31.3 kW*



ISO 9002 Certified KUBOTA ENGINE PLANTS - SAKAI/TSUKUBA/SAKAI-RINKAI-

# Specifications



**D905**



**D1005**



**D1105**



**D1105-T**



**V1305**



**V1505**



**V1505-T**

Type		Vertical 4-cycle liquid cooled Diesel			Vertical 4-cycle liquid cooled Diesel				
No. of Cylinders		3			3	4			
Bore x Stroke		mm (in)	72.0 x 73.6 (2.83 x 2.90)	76.0 x 73.6 (2.99 x 2.90)	78.0 x 78.4 (3.07 x 3.09)	76.0 x 73.6 (2.99 x 2.90)	78.0 x 78.4 (3.07 x 3.09)		
Total Displacement		L (cu.in.)	0.898 (54.8)	1.001 (61.08)	1.123 (68.53)	1.335 (81.47)	1.498 (91.41)		
Combustion System		E-TVCS							
Intake System		Natural aspirated			Turbo charged	Natural aspirated			
Output	Gross Intermittent	kW (HP)/rpm	15.5 (20.8)/3000	17.5 (23.5)/3000	19.4 (26.0)/3000	24.5 (32.8)/3000	23.4 (31.4)/3000	26.5 (35.5)/3000	33.0 (44.2)/3000
			18.5 (24.8)/3600	20.4 (27.3)/3600	-	-	27.2 (36.5)/3600	-	-
	Net Intermittent	kW (HP)/rpm	14.9 (20.0)/3000	16.8 (22.5)/3000	18.7 (25.0)/3000	23.5 (31.5)/3000	22.4 (30.0)/3000	25.0 (33.5)/3000	31.3 (42.0)/3000
			17.5 (23.5)/3600	19.4 (26.0)/3600	-	-	25.7 (34.5)/3600	-	-
Net Continuous	kW (HP)/rpm	13.0 (17.4)/3000	14.5 (19.5)/3000	16.2 (21.7)/3000	20.4 (27.4)/3000	19.4 (26.0)/3000	21.7 (29.1)/3000	27.2 (36.5)/3000	
		15.2 (20.4)/3600	16.8 (22.5)/3600	-	-	22.4 (30.0)/3600	-	-	
No Load High Idling Speed		rpm	3800			3200	3800		3200
No Load Low Idling Speed		rpm	800						
Direction of Rotation		Counterclockwise (viewed from flywheel side)			Counterclockwise (viewed from flywheel side)				
Governing		Centrifugal flyweight mechanical type governor			Centrifugal flyweight mechanical type governor				
Fuel		Diesel fuel No. 2-D (ASTM D975)							
Starter Capacity		V-A	12-0.9	12-1.0	12-1.0	12-1.2	12-1.0		
Alternator Capacity		V-A	12-12.5	12-30	12-30	12-30	12-30		
Dry Weight	With Rear-End Plate	kg (lbs)	93.0 (205.0)			97.0 (213.8)	110.0 (242.5)	114.0 (251.3)	
	With SAE Flywheel and Housing	kg (lbs)	110.0 (242.5)			110.0 (242.5)	127.0 (280.0)	131.0 (288.8)	

\*Specifications are subject to change without notice.  
\*Dry weight is according to Kubota's standard specification. When specification varies, the weight will vary accordingly.

# Performance Curve

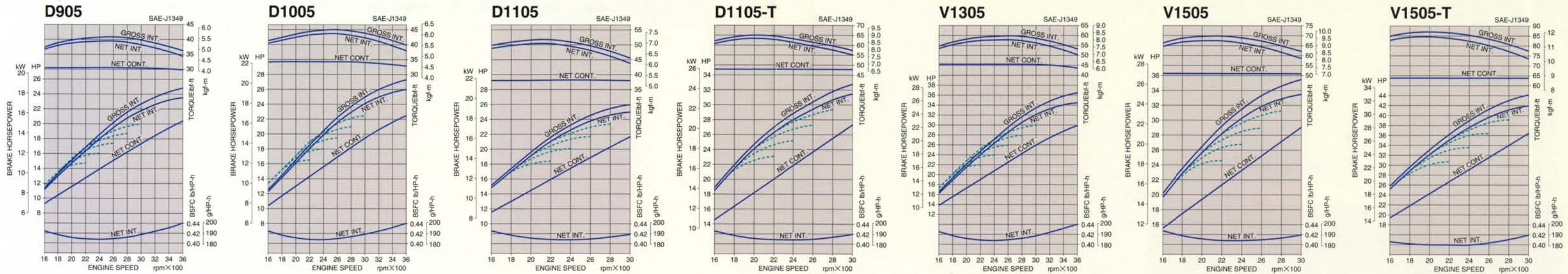

## Dimensions: mm (inch)

**D905  
D1005  
D1105  
D1105-T**

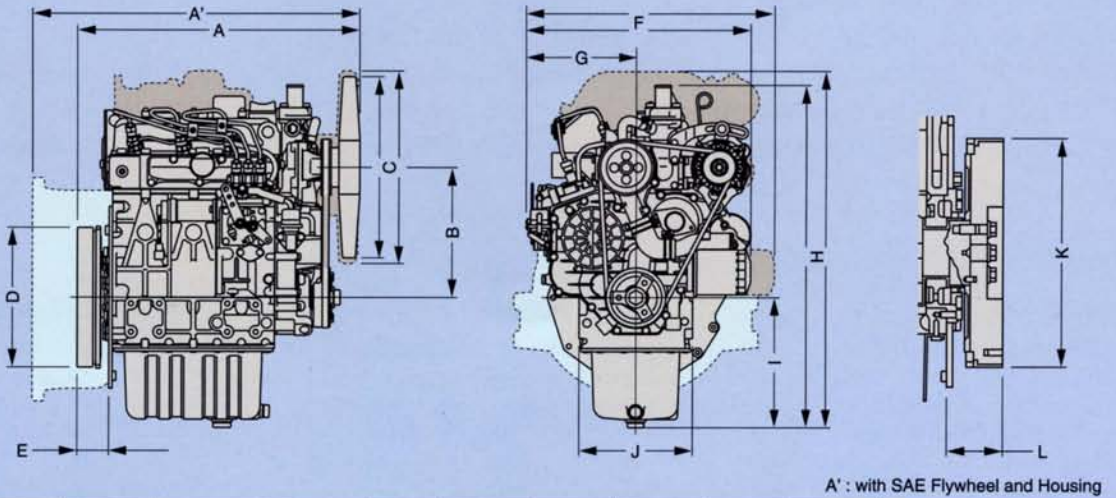

	A	A'	B	C	D	E	F	G	H	I	J	K	L
D905	497.8(19.60)	566.8(22.31)	230.0(9.06)	φ320.0(φ12.60)	φ247.0(φ9.72)	56.0(2.20)	396.0(15.59)	194.0(7.64)	604.7(23.81)	229.5(9.04)	200.0(7.87)	φ251.17 <sup>+0.05</sup> <sub>-0.36</sub> (φ9.89 <sup>-0.00197</sup> <sub>-0.01417</sub> )	56.0(2.20)
D1005/D1105	497.8(19.60)	566.8(22.31)	230.0(9.06)	φ330.0(φ12.99)	φ247.0(φ9.72)	56.0(2.20)	396.0(15.59)	194.0(7.64)	604.7(23.81)	229.5(9.04)	200.0(7.87)	φ251.17 <sup>+0.05</sup> <sub>-0.36</sub> (φ9.89 <sup>-0.00197</sup> <sub>-0.01417</sub> )	62.0(2.44)
D1105-T	494.6(19.47)	563.6(22.19)	230.0(9.06)	φ340.0(φ13.39)	φ247.0(φ9.72)	56.0(2.20)	437.7(17.23)	194.0(7.64)	628.8(24.76)	229.5(9.04)	200.0(7.87)	-	-

**V1305  
V1505  
V1505-T**

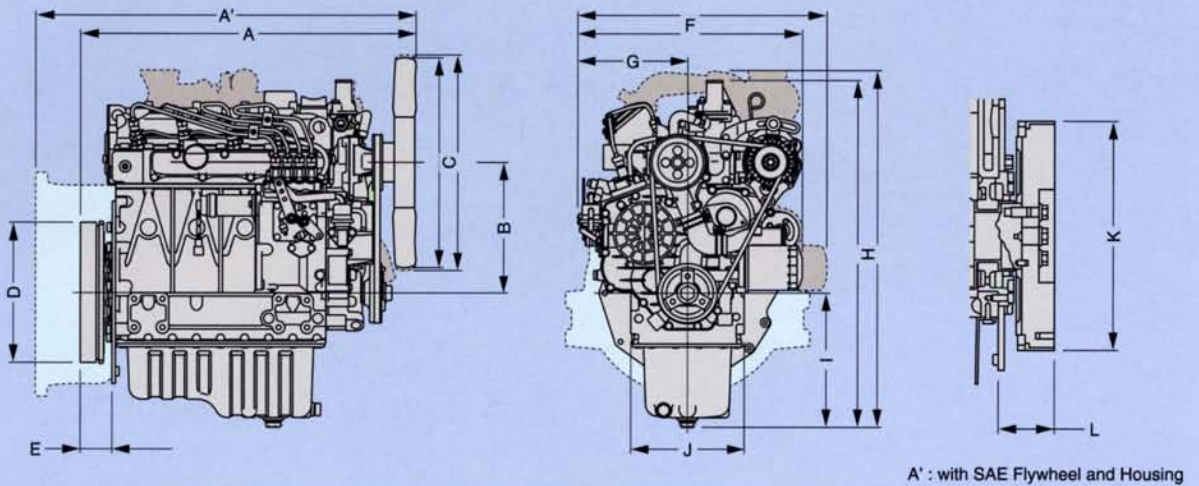

	A	A'	B	C	D	E	F	G	H	I	J	K	L
V1305	583.8(22.98)	652.8(25.70)	230.0(9.06)	φ350.0(φ13.78)	φ247.0(φ9.72)	56.0(2.20)	396.0(15.59)	194.0(7.64)	609.7(24.00)	234.5(9.23)	200.0(7.87)	φ251.17 <sup>+0.05</sup> <sub>-0.36</sub> (φ9.89 <sup>-0.00197</sup> <sub>-0.01417</sub> )	62.0(2.44)
V1505	591.3(23.28)	652.8(25.70)	230.0(9.06)	φ370.0(φ14.57)	φ247.0(φ9.72)	56.0(2.20)	396.0(15.59)	194.0(7.64)	609.7(24.00)	234.5(9.23)	200.0(7.87)	φ251.17 <sup>+0.05</sup> <sub>-0.36</sub> (φ9.89 <sup>-0.00197</sup> <sub>-0.01417</sub> )	62.0(2.44)
V1505-T	591.3(23.28)	660.3(26.00)	230.0(9.06)	φ380.0(φ14.96)	φ247.0(φ9.72)	56.0(2.20)	439.2(17.29)	194.0(7.64)	627.3(24.70)	234.5(9.23)	200.0(7.87)	-	-

## SAE Flywheel and Housing: mm (inch)

**SAE NO.5 Housing**

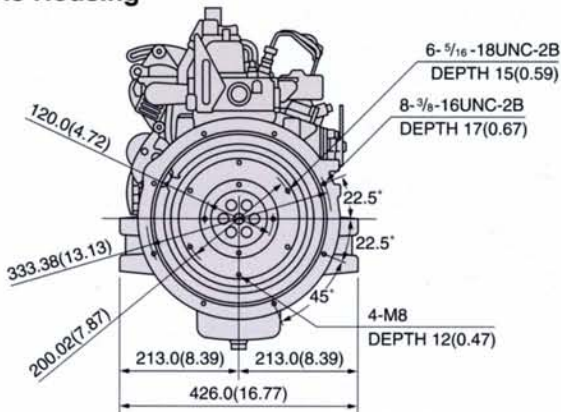

**Clutch NO.6 1/2 Flywheel**

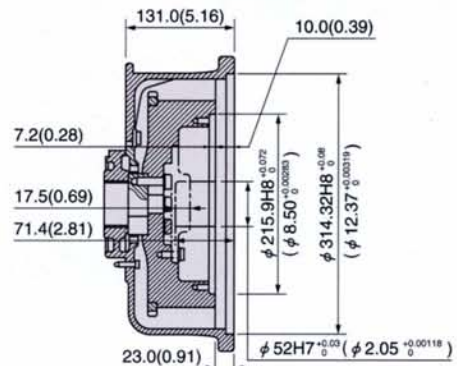

# A world leader in Industrial Engine Technology, KUBOTA.

Kubota's longstanding devotion to research and development has earned us a growing reputation worldwide as a manufacturer of top quality diesel engines. One of Kubota's major concerns has always been the development of a more compact, fuel efficient, and cleaner exhaust engine. Our long technical experience, untiring research, and deep concern for the environment led to the creation of the SUPER FIVE series.

## Outstanding Features

### Low Noise

The SUPER FIVE series' already existing low noise levels during load and no-load operations were further reduced by 1 ~ 1.5 dBA with the help of the E-TVCS, standard built-in steel strut Offset Piston, and the increased rigidity of the crank and gear cases.

### Large Capacity, High Speed Flyweight Governor

Instead of the conventional ball type governor, a large capacity, high speed flyweight governor is used. This ensures stable operation at a low revolution speed, high torque rise, and Stead State Governor Regulation.

### Quick Start Ups

Super glow system comes as standard equipment to shorten preheating time and quicken engine start up in cold temperatures.

### Highly Reliable Engine

Based on Kubota's original sturdy design, the engine promises great reliability and long service life with advantages to meet most any application.

### Increased PTO Capacity for Beltdrive

The crankshaft has enough diameter, strength and main bearing area to meet various applications and to handle heavy loads.

### Pollution-Free Design

In addition to the excellent features such as clean exhaust and low noise, we have also designed them against asbestos pollution.

### Accessories/Options

A full range of accessories and options are available to meet customer's demand.

### Friendly To The Environment

Kubota was the first manufacturer to pass the U.S. CARB ULGE emission regulations for engines under 25HP. All Kubota-made diesel engines are now in compliance with the U.S. E.P.A., the European EC, and the Japanese MOC regulations. Kubota will continue to work aggressively toward meeting all future emission standards.

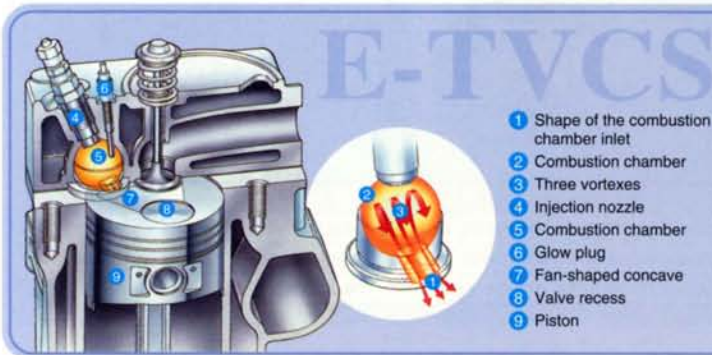

## E-TVCS Technology Improves Engine Performances

The concave recess on the piston head helps Kubota's E-TVCS (Three Vortex Combustion System) generate three intense swirling air flow (vortexes) within the spherical-combustion chamber to obtain an optimum air/fuel mixture. This superb combustion system improves the power output, fuel economy, and engine start ups, while reducing both noise and toxic emissions.

- 1 Shape of the combustion chamber inlet
- 2 Combustion chamber
- 3 Three vortexes
- 4 Injection nozzle
- 5 Combustion chamber
- 6 Glow plug
- 7 Fan-shaped concave
- 8 Valve recess
- 9 Piston

## Model Line-Up

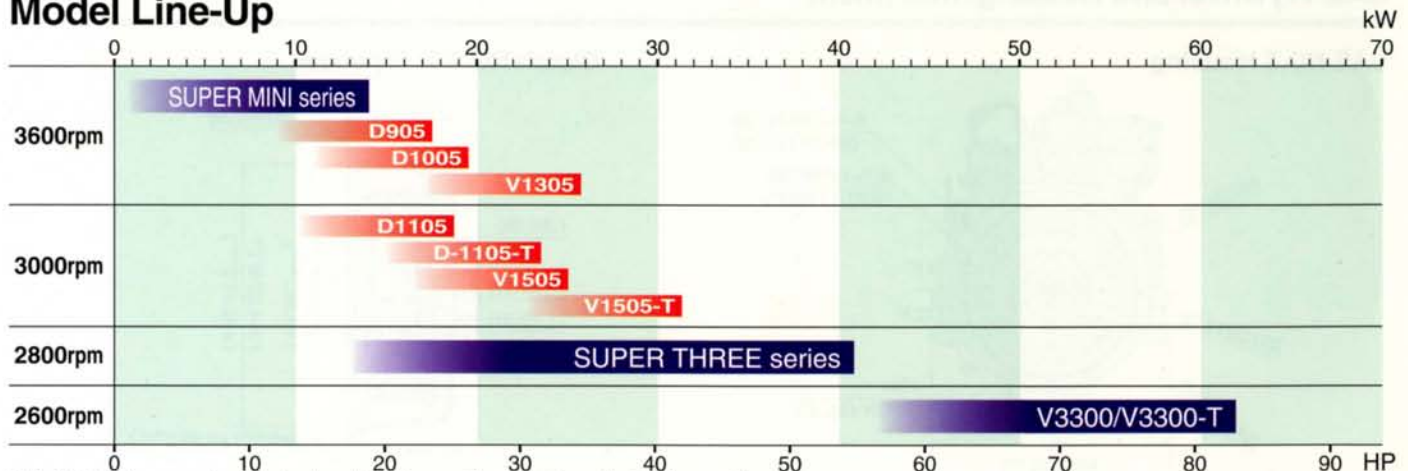

\*Note: This is only an approximation of each model's kW range. Please refer to specifications for exact figures.

# YOUR "BEST BUSINESS PARTNER"

KUBOTA's goal is not only to be your engine supplier, but to be your "BEST BUSINESS PARTNER" by providing you with comprehensive strengths. KUBOTA's "High Quality", "Flexible Power Range" diesel engines will provide you more than just dependable power, but the power to move your business further ahead.

## Manufacturing Facilities

KUBOTA is one of the few engine manufacturers that produces engines from the casting level. In order to ensure optimum quality and customer satisfaction, KUBOTA has installed and will continue to upgrade its "state of the art" manufacturing facilities.



Automatic assembly line  
(piston installation)



ES casting line

## Quality Control & Emission Control

KUBOTA enforces stringent quality & emission test standards to create powerful, clean emission, quiet running, and virtually maintenance-free engines.



The emission test room at KUBOTA R&D Center

## Support

KUBOTA's WWS (World-Wide Service) Network covers 50 countries around the world to serve you.

## Application Engineering

KUBOTA is actively involved from the very beginning in the Research and Development process of your products to provide the "Best-Matching" engine for your application.

\*Specifications and dimensions are subject to change without prior notice.

# Kubota

## Kubota Engine America Corporation

5900 Schelter Road, Lincolnshire, IL 60069

Phone: 847-955-2500 Fax: 847-955-2699

<http://www.kubotaengine.com>

## Kubota Canada Ltd.

Engine Division:

5900 14th Avenue, Markham, Ontario L3S 4K4, Canada

Phone: 905-294-7477 Fax: 905-294-6651

<http://www.dieselnet.com/kubota>