

# POWERLINE<sup>®</sup>

## GENERATORS

Model KS3600 – 36 kWe\*

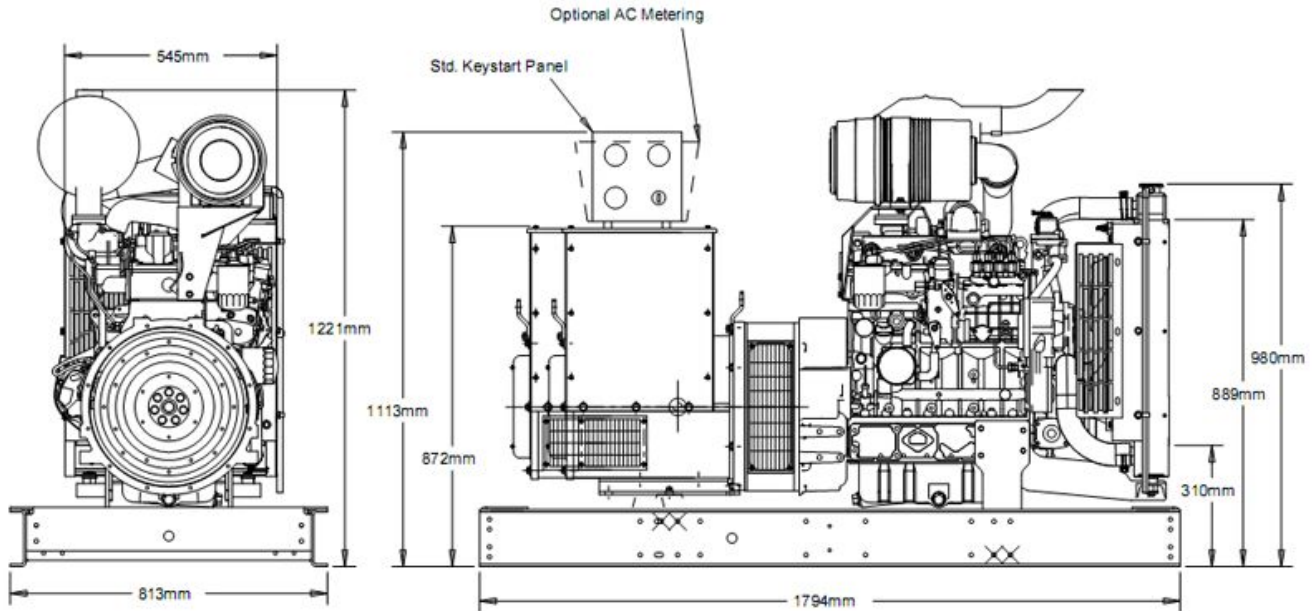

KUBOTA V3300T WITH UCI 224 C / D / E

Approx dry weight without battery:  
- 600 kg (1320 lbs)

*This drawing is for general information only – not for installation purposes.  
Specifications, dimensions or ratings may be changed without notice.*

### General Information\*

- The generator set rating is 33 kilowatts prime power output and 36 kilowatts intermittent power output. These ratings are based upon standard rating conditions. It may be necessary to derate the output for altitudes above 1000' (300 meters) or for ambient temperatures above 104°F (40°C). Please contact Frontier Power Products for details on ratings criteria for the engine and generator or for derate information.
- The engine and brushless four pole AC generator are directly coupled and mounted on a rugged steel base frame. All components are suitable for prime or intermittent usage.
- The entire set is thoroughly load tested prior to shipment.

### Standard Engine

- Kubota diesel model V3300TBG. In-line, four cylinder engine with full flow, replaceable lube oil, fuel and air filters. Mechanical speed governing provides +/- 3 to 5% speed regulation, no load to full load.

- Liquid cooled with industrial grade radiator and belt driven blower fan.
- SAE housing and flywheel directly connected to the single bearing generator.

### Standard Generator

- Newage Stamford brushless, four pole (1800 rpm) generator.
- Solid state, +/- 1½% automatic voltage regulation.
- CSA approved construction.

### Standard Controls and Accessories

- Key start panel with oil pressure, coolant temperature, hour meter and glow plug indicator, resettable DC breaker protection
- Manual safety shutdown over-ride, fuse protection.
- Automatic safety shutdowns, energized-to-run, for low oil pressure/high coolant temperature.
- Four anti-vibration mounts between generator set and base frame.
- Electric fuel transfer and priming pump (12 VDC).
- Battery rack and cables (no battery) for 12 VDC starting system. (Optional battery available)

## POWERLINE KS3600 Specifications

### Engine Technical Information

Manufacturer	Kubota
Model	V3300TBG
Cylinders	Four
Bore X Stroke	98mm X 110mm (3.86" X 4.33")
Displacement	3.3 litres (203 c.i.d.)
Output, intermittent	43.1 kWm (58.6 HP)
Output, continuous	39.2 kWm (53.2 HP)
Comp. ratio	23:1
Engine weight	250 kg (551 lbs.) dry

### Fuel System

Fuel type	#2 Diesel
Injection pump	Bosch
Injectors	Throttle type
Transfer pump	Electric, 12VDC
Fuel lift	1 meter (3.3 ft.)
Suction fitting	5/16" push-on
Return fitting	3/16" push-on
Fuel use @ 100%	11.8 litre/hr. @ 36 kWe
Fuel use @ 75%	9.2 litre/hr. @ 24 kWe
Fuel use @ 50%	6.8 litre/hr. @ 18 kWe

*Actual fuel consumption varies with site conditions and fuel energy content.*

### Lube Oil System

Grade	API "CD/CE"
> 25°C (77°F)	SAE30, SAE10W-30 or SAE10W-40
0°-25°C(32°-77°F)	SAE20, SAE10W-30 or SAE10W-40
< 0°C (32°F)	SAE10W, SAE10W-30 or SAE10W-40
Capacity	13.2 liters (3.5 US gal.)
Filter	Full flow, spin-on

### Air Intake System

Filter	Replaceable element
Combustion air @1800 rpm	3.6 m <sup>3</sup> /min. (127 cfm)
Restriction	500mm (20") max.(H <sub>2</sub> O)

### DC Electrical System

Starter	12V, 2.5 kW
Alternator	12V, 45A
Glow plug	QGS type
Battery required	12V 700 CCA @ 0°C min.
Run solenoid	12V, ETR

### Cooling System

Radiator	Finned tube type
Material	Copper core, soldered tanks
Pressure	88 kPa (12.9 psi) max
Fan type	Blower, Nylon
Water pump	Gear case mounted
Type	Centrifugal, belt drive
Thermostat	Wax pellet type
Stat. cracking temp.	71°C (160°F)

### Cooling System, cont'd.

Fully open stat. temp.	85°C (185°F)
Recommended coolant	50/50*
<i>*Use low silicate ethylene glycol and high quality water. Consult manufacturer for details.</i>	
Air-to-boil @ 36 kWe	50°C (122°F)
Cooling air required	82 m <sup>3</sup> /min (2,890 ft <sup>3</sup> /min)

### Exhaust System

Muffler type	Industrial grade
Mounting	Vertical with rain cap
Restriction	38 mm (1.5") Hg max.

### Noise Level @ 1 m (3.3')

*Levels are with industrial grade muffler and open (no enclosure) configuration.*

Full load, inter.	88.7 dB(A)
Full load, prime	88.5 dB(A)
No load	87.5 dB(A)

### Generator Technical Information

Manufacturer	Newage/Stamford
Model	UCI224
Construction	Four pole, brushless Open drip-proof (IP23) Single bearing
Weight	250 kg (550 lbs.)
Cooling air flow	16.9 m <sup>3</sup> /min (596 cfm)
Leads	4 or 12, application dependent

60 Hz. voltages and ratings (prime/intermittent)

- 33/36 kW, 41/45 kVA @ 120/208 3 phase
- 33/36 kW, 41/45 kVA @ 277/480 3 phase

*Single phase ratings are available*

*Other voltages and 50 Hz ratings are available.*

Power Factor	1 phase ratings @ 1.0 PF 3 phase. ratings @ 0.8 PF
Voltage regulation	SX460 solid state +/- 1½% no load to full load
Temperature rise	105°C rise Prime (40°C ambient) 125°C rise Intermit. (40°C)
Telephone. interference	TIF < 50
Winding pitch	Two thirds
Control system	Self excited
Inrush examples	110 kVA @ 480V @ 30% dip 82 kVA @ 208V @ 30% dip

### Ancillary Equipment

Mounting	Steel base with mounting holes
Isolators	Four composite mounts

*Please see the comprehensive option list.*



CSA approved construction

**frontier**  
**POWER PRODUCTS**

**www.frontierpower.com**

Delta, BC, Canada (604) 946-5531  
Edmonton, AB, Canada (780) 455-2260  
Calgary, AB, Canada (403) 720-3735